

# 7

## Solar Power

This chapter provides an introduction to the components of a **standalone photovoltaic system**. The word standalone refers to the fact that the system works without any connection to an established power grid. In this chapter, we will present the basic concepts of the generation and storage of photovoltaic solar energy. We will also provide a method for designing a functional solar system with limited access to information and resources.

This chapter only discusses the use of solar energy for the direct production of electricity (**photovoltaic solar energy**). Solar energy can also be used to heat fluids (**thermal solar energy**) which can then be used as a heat source or to turn a turbine to generate electricity. Thermal solar energy systems are beyond the scope of this chapter.

### *Solar energy*

A photovoltaic system is based on the ability of certain materials to convert the radiant energy of the sun into electrical energy. The total amount of solar energy that lights a given area is known as **irradiance (G)** and it is measured in **watts per square meter ( $W/m^2$ )**. The instantaneous values are normally averaged over a period of time, so it is common to talk about total irradiance per hour, day or month.

Of course, the precise amount of radiation that arrives at the surface of the Earth cannot be predicted with high precision, due to natural weather variations. Therefore it is necessary to work with statistical data based on the "solar history" of a particular place. This data is gathered by a weather station over a long period and is available from a number of sources, as tables or

databases. In most cases, it can be difficult to find detailed information about a specific area, and you will need to work with approximate values.

A few organizations have produced maps that include average values of daily global irradiation for different regions. These values are known as **peak sun hours** or **PSHs**. You can use the PSH value for your region to simplify your calculations. One unit of "peak sun" corresponds to a radiation of 1000 Watts per square meter. If we find that certain area has 4 PSH in the worst of the months, it means that in that month we should not expect a daily irradiation bigger than 4000 W/m<sup>2</sup> (day). The peak sun hours are an easy way to represent the worst case average of irradiation per day.

Low resolution PSH maps are available from a number of online sources, such as <http://www.solar4power.com/solar-power-global-maps.html>. For more detailed information, consult a local solar energy vendor or weather station.

## What about wind power?

It is possible to use a wind generator in place of solar panels when an autonomous system is being designed for installation on a hill or mountain. To be effective, the average wind speed over the year should be at least 3 to 4 meter per second, and the wind generator should be 6 meters higher than other objects within a distance of 100 meters. A location far away from the coast usually lacks sufficient wind energy to support a wind powered system.

Generally speaking, photovoltaic systems are more reliable than wind generators, as sunlight is more available than consistent wind in most places. On the other hand, wind generators are able to charge batteries even at night, as long as there is sufficient wind. It is of course possible to use wind in conjunction with solar power to help cover times when there is extended cloud cover, or when there is insufficient wind.

For most locations, the cost of a good wind generator is not justified by the meager amount of power it will add to the overall system. This chapter will therefore focus on the use of solar panels for generating electricity.

## Photovoltaic system components

A basic photovoltaic system consists of four main components: the **solar panel**, the **batteries**, the **regulator**, and the **load**. The panels are responsible for collecting the energy of the sun and generating electricity. The battery stores the electrical energy for later use. The regulator ensures that panel and battery are working together in an optimal fashion. The load refers to any device that requires electrical power, and is the sum of the consumption of all

electrical equipment connected to the system. It is important to remember that solar panels and batteries use **direct current (DC)**.

If the range of operational voltage of your equipment does not fit the voltage supplied by your battery, it will also be necessary to include some type of **converter**. If the equipment that you want to power uses a different DC voltage than the one supplied by the battery, you will need to use a **DC/DC converter**. If some of your equipment requires AC power, you will need to use a **DC/AC converter**, also known as an **inverter**.

Every electrical system should also incorporate various safety devices in the event that something goes wrong. These devices include proper wiring, circuit breakers, surge protectors, fuses, ground rods, lighting arrestors, etc.

## The solar panel

The **solar panel** is composed of solar cells that collect solar radiation and transform it into electrical energy. This part of the system is sometimes referred to as a **solar module** or **photovoltaic generator**. **Solar panel arrays** can be made by connecting a set of panels in series and/or parallel in order to provide the necessary energy for a given load. The electrical current supplied by a solar panel varies proportionally to the solar radiation. This will vary according to climatological conditions, the hour of the day, and the time of the year.

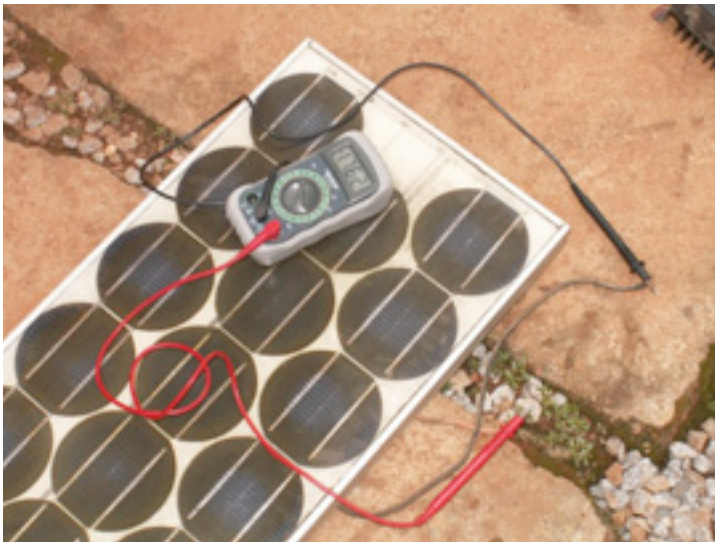

Figure 7.1: A solar panel

Several technologies are used in the manufacturing of solar cells. The most common is crystalline silicon, and can be either monocrystalline or polycrystalline. Amorphous silicon can be cheaper but is less efficient at converting solar

energy to electricity. With a reduced life expectancy and a 6 to 8% transformation efficiency, amorphous silicon is typically used for low power equipment, such as portable calculators. New solar technologies, such as silicon ribbon and thin film photovoltaics, are currently under development. These technologies promise higher efficiencies but are not yet widely available.

## The battery

The **battery** stores the energy produced by the panels that is not immediately consumed by the load. This stored energy can then be used during periods of low solar irradiation. The battery component is also sometimes called the **accumulator**. Batteries store electricity in the form of chemical energy. The most common type of batteries used in solar applications are **maintenance-free lead-acid batteries**, also called **recombinant** or **VRLA (valve regulated lead acid)** batteries.



*Figure 7.2: A 200 Ah lead-acid battery. The negative terminal was broken due to weight on the terminals during transportation.*

Aside from storing energy, sealed lead-acid batteries also serve two important functions:

- They are able to provide an instantaneous power superior to what the array of panels can generate. This instantaneous power is needed to start some appliances, such as the motor of a refrigerator or a pump.
- They determine the operating voltage of your installation.

For a small power installation and where space constraints are important, other type of batteries (such as NiCd, NiMh, or Li-ion) can be used. These types of batteries need a specialized charger/regulator and cannot directly replace lead-acid batteries.

## The regulator

The **regulator** (or more formally, the **solar power charge regulator**) assures that the battery is working in appropriate conditions. It avoids **overcharging** or **overdischarging** the battery, both of which are very detrimental to the life of the battery. To ensure proper charging and discharging of the battery, the regulator maintains knowledge of the **state of charge (SoC)** of the battery. The SoC is estimated based on the actual voltage of the battery. By measuring the battery voltage and being programmed with the type of storage technology used by the battery, the regulator can know the precise points where the battery would be overcharged or excessively discharged.



Figure 7.3: A 30 Amp solar charge controller

The regulator can include other features that add valuable information and security control to the equipment. These features include ammeters, voltmeters, measurement of ampere-hour, timers, alarms, etc. While convenient, none of these features are required for a working photovoltaic system.

## The converter

The electricity provided by the panel array and battery is DC at a fixed voltage. The voltage provided might not match what is required by your load. A **direct/alternating (DC/AC) converter**, also known as **inverter**, converts

the DC current from your batteries into AC. This comes at the price of losing some energy during the conversion. If necessary, you can also use converters to obtain DC at voltage level other than what is supplied by the batteries. **DC/DC converters** also lose some energy during the conversion. For optimal operation, you should design your solar-powered system to match the generated DC voltage to match the load.



Figure 7.4: An 800 Watt DC/AC converter (power inverter)

## The load

The **load** is the equipment that consumes the power generated by your energy system. The load may include wireless communications equipment, routers, workstations, lamps, TV sets, VSAT modems, etc. Although it is not possible to precisely calculate the exact total consumption of your equipment, it is vital to be able to make a good estimate. In this type of system it is absolutely necessary to use efficient and low power equipment to avoid wasting energy.

## Putting it all together

The complete photovoltaic system incorporates all of these components. The solar panels generate power when solar energy is available. The regulator ensures the most efficient operation of the panels and prevents damage to the batteries. The battery bank stores collected energy for later use. Converters and inverters adapt the stored energy to match the requirements of your load. Finally, the load consumes the stored energy to do work. When all of the components are in balance and are properly maintained, the system will support itself for years.

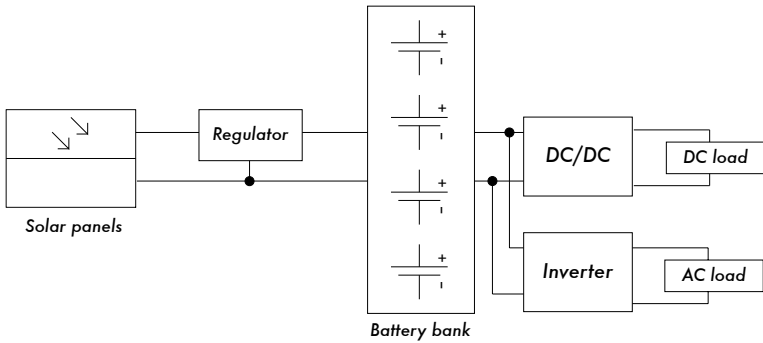

Figure 7.5: A solar installation with DC and AC loads

We will now examine each of the individual components of the photovoltaic system in greater detail.

## The solar panel

An individual solar panel is made of many solar cells. The cells are electrically connected to provide a particular value of current and voltage. The individual cells are properly encapsulated to provide isolation and protection from humidity and corrosion.



Figure 7.6: The effect of water and corrosion in a solar panel

There are different types of modules available on the market, depending on the power demands of your application. The most common modules are composed of 32 or 36 solar cells of crystalline silicon. These cells are all of equal size, wired in series, and encapsulated between glass and plastic ma-

terial, using a polymer resin (EVA) as a thermal insulator. The surface area of the module is typically between 0.1 and 0.5 m<sup>2</sup>. Solar panels usually have two electrical contacts, one positive and one negative.

Some panels also include extra contacts to allow the installation of **bypass diodes** across individual cells. Bypass diodes protect the panel against a phenomenon known as “hot-spots”. A hot-spot occurs when some of the cells are in shadow while the rest of the panel is in full sun. Rather than producing energy, shaded cells behave as a load that dissipates energy. In this situation, shaded cells can see a significant increase in temperature (about 85 to 100°C.) Bypass diodes will prevent hot-spots on shaded cells, but reduce the maximum voltage of the panel. They should only be used when shading is unavoidable. It is a much better solution to expose the entire panel to full sun whenever possible.

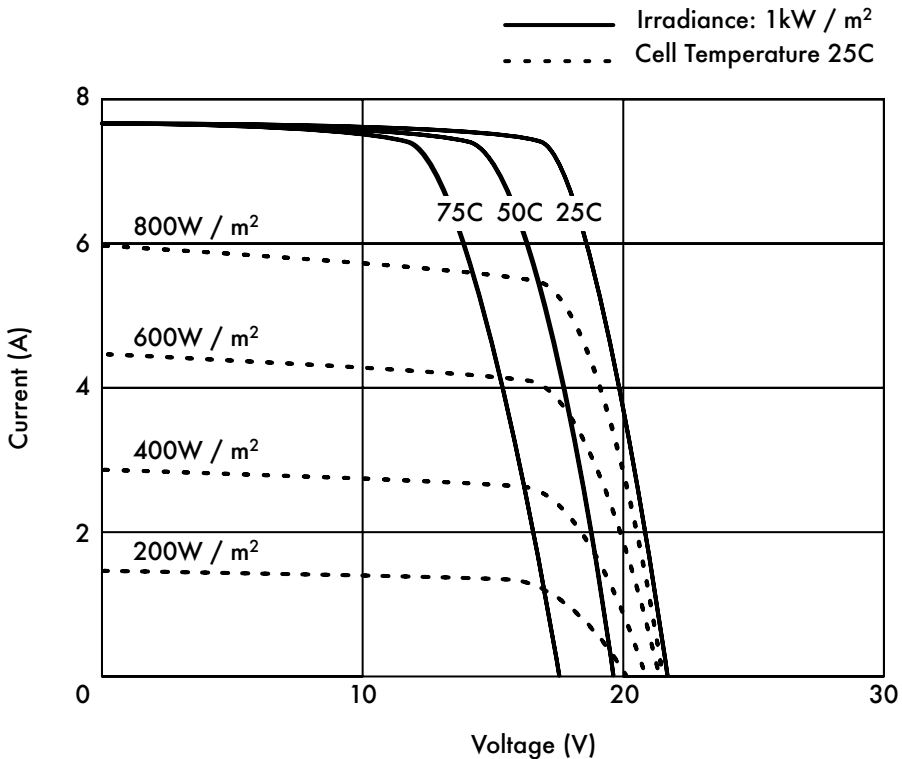

Figure 7.7: Different IV Curves. The current (A) changes with the irradiance, and the voltage (V) changes with the temperature.

The electrical performance of a solar module is represented by the **IV characteristic curve**, which represents the current that is provided based on the voltage generated for a certain solar radiation.



The curve represents all the possible values of voltage-current. The curves depend on two main factors: the temperature and the solar radiation received by the cells. For a given solar cell area, the current generated is directly proportional to solar irradiance ( $G$ ), while the voltage reduces slightly with an increase of temperature. A good regulator will try to maximize the amount of energy that a panel provides by tracking the point that provides maximum power ( $V \times I$ ). The maximum power corresponds to the knee of the IV curve.

## Solar Panel Parameters

The main parameters that characterize a photovoltaic panel are:

1. **SHORT CIRCUIT CURRENT** ( $I_{SC}$ ): the maximum current provided by the panel when the connectors are short circuited.
2. **OPEN CIRCUIT VOLTAGE** ( $V_{OC}$ ): the maximum voltage that the panel provides when the terminals are not connected to any load (an open circuit). This value is normally 22 V for panels that are going to work in 12 V systems, and is directly proportional to the number of cells connected in series.
3. **MAXIMUM POWER POINT** ( $P_{max}$ ): the point where the power supplied by the panel is at maximum, where  $P_{max} = I_{max} \times V_{max}$ . The maximum power point of a panel is measured in Watts (W) or peak Watts ( $W_p$ ). It is important not to forget that in normal conditions the panel will not work at peak conditions, as the voltage of operation is fixed by the load or the regulator. Typical values of  $V_{max}$  and  $I_{max}$  should be a bit smaller than the  $I_{SC}$  and  $V_{OC}$ .
4. **FILL FACTOR** (FF): the relation between the maximum power that the panel can actually provide and the product  $I_{SC} \cdot V_{OC}$ . This gives you an idea of the quality of the panel because it is an indication of the type of IV characteristic curve. The closer FF is to 1, the more power a panel can provide. Common values usually are between 0.7 and 0.8.
5. **EFFICIENCY** ( $h$ ): the ratio between the maximum electrical power that the panel can give to the load and the power of the solar radiation ( $P_L$ ) incident on the panel. This is normally around 10-12%, depending on the type of cells (monocrystalline, polycrystalline, amorphous or thin film).

Considering the definitions of point of maximum power and the fill factor we see that:

$$h = P_{max} / P_L = FF \cdot I_{SC} \cdot V_{OC} / P_L$$

The values of  $I_{SC}$ ,  $V_{OC}$ ,  $I_{Pmax}$  and  $V_{Pmax}$  are provided by the manufacturer and refer to standard conditions of measurement with irradiance  $G = 1000 \text{ W/m}^2$ , at sea-level, for a temperature of cells of  $T_c = 25^\circ\text{C}$ .

The panel parameters values change for other conditions of irradiance and temperature. Manufacturers will sometimes include graphs or tables with values for conditions different from the standard. You should check the performance values at the panel temperatures that are likely to match your particular installation.

Be aware that two panels can have the same  $W_p$  but very different behavior in different operating conditions. When acquiring a panel, it is important to verify, if possible, that their parameters (at least,  $I_{SC}$  and  $V_{OC}$ ) match the values promised by the manufacturer.

## Panel parameters for system sizing

To calculate the number of panels required to cover a given load, you just need to know the current and voltage at the point of maximum power:  $I_{Pmax}$  and  $V_{Pmax}$ .

You should always be aware that the panel is not going to perform under perfect conditions as the load or regulation system is not always going to work at the point of maximum power of the panel. You should assume a loss of efficiency of 5% in your calculations to compensate for this.

## Interconnection of panels

A **solar panel array** is a collection of solar panels that are electrically interconnected and installed on some type of support structure. Using a solar panel array allows you to generate greater voltage and current than is possible with a single solar panel. The panels are interconnected in such a way that the voltage generated is close to (but greater than) the level of voltage of the batteries, and that the current generated is sufficient to feed the equipment and to charge the batteries.

Connecting solar panels in series increases the generated voltage. Connecting panels in parallel increases the current. The number of panels used should be increased until the amount of power generated slightly exceeds the demands of your load.

It is very important that all of the panels in your array are as identical as possible. In an array, you should use panels of the same brand and characteristics because any difference in their operating conditions will have a big impact on the health and performance of your system. Even panels that have identical

performance ratings will usually display some variance in their characteristics due to manufacturing processes. The actual operating characteristics of two panels from the same manufacturer can vary by as much as  $\pm 10\%$ .

Whenever possible, it is a good idea to test the real-world performance of individual panels to verify their operating characteristics before assembling them into an array.

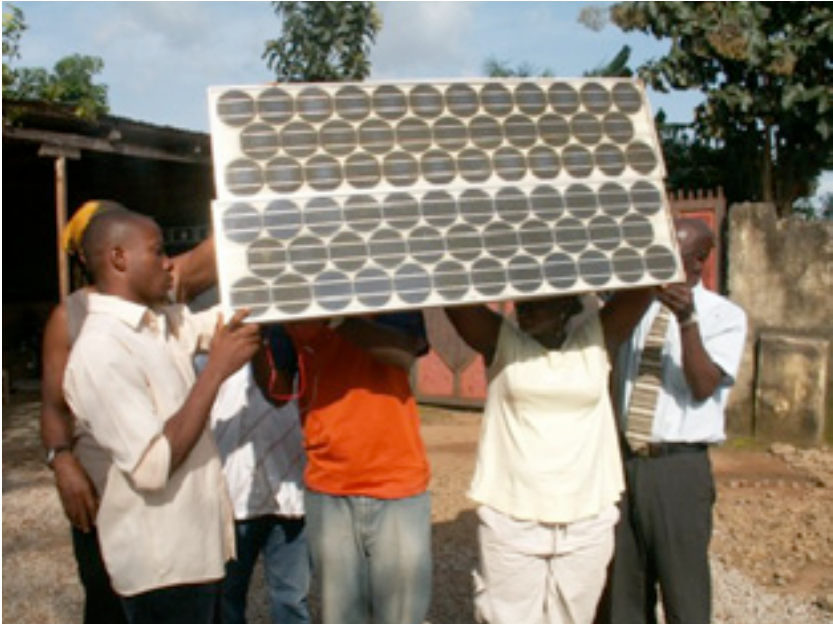

*Figure 7.8: Interconnection of panels in parallel. The voltage remains constant while the current duplicates. (Photo: Fantsuam Foundation, Nigeria)*

## How to choose a good panel

One obvious metric to use when shopping for solar panels is to compare the ratio of the nominal peak power ( $W_p$ ) to the price. This will give you a rough idea of the cost per Watt for different panels. But there are a number of other considerations to keep in mind as well.

If you are going to install solar panels in geographical areas where soiling (from dust, sand, or grit) will likely be a problem, consider purchasing panels with a low affinity for soil retention. These panels are made of materials that increase the likelihood that the panel will be automatically cleaned by wind and rain.

Always check the mechanical construction of each panel. Verify that the glass is hardened and the aluminum frame is robust and well built. The solar

cells inside the panel can last for more than 20 years, but they are very fragile and the panel must protect them from mechanical hazards. Look for the manufacturer's quality guarantee in terms of expected power output and mechanical construction.

Finally, be sure that the manufacturer provides not only the nominal peak power of the panel ( $W_p$ ) but also the variation of the power with irradiation and temperature. This is particularly important when panels are used in arrays, as variations in the operating parameters can have a big impact on the quality of power generated and the useful lifetime of the panels.

## The battery

The battery “hosts” a certain reversible chemical reaction that stores electrical energy that can later be retrieved when needed. Electrical energy is transformed into chemical energy when the battery is being charged, and the reverse happens when the battery is discharged.

A battery is formed by a set of elements or **cells** arranged in series. Lead-acid batteries consist of two submerged lead electrodes in an electrolytic solution of water and sulfuric acid. A potential difference of about 2 volts takes place between the electrodes, depending on the instantaneous value of the charge state of the battery. The most common batteries in photovoltaic solar applications have a nominal voltage of 12 or 24 volts. A 12 V battery therefore contains 6 cells in series.

The battery serves two important purposes in a photovoltaic system: to provide electrical energy to the system when energy is not supplied by the array of solar panels, and to store excess energy generated by the panels whenever that energy exceeds the load. The battery experiences a cyclical process of charging and discharging, depending on the presence or absence of sunlight. During the hours that there is sun, the array of panels produces electrical energy. The energy that is not consumed immediately it is used to charge the battery. During the hours of absence of sun, any demand of electrical energy is supplied by the battery, thereby discharging it.

These cycles of charge and discharge occur whenever the energy produced by the panels does not match the energy required to support the load. When there is sufficient sun and the load is light, the batteries will charge. Obviously, the batteries will discharge at night whenever any amount of power is required. The batteries will also discharge when the irradiance is insufficient to cover the requirements of the load (due to the natural variation of climatological conditions, clouds, dust, etc.)

If the battery does not store enough energy to meet the demand during periods without sun, the system will be exhausted and will be unavailable for consumption. On the other hand, the oversizing the system (by adding far too many panels and batteries) is expensive and inefficient. When designing a stand-alone system we need to reach a compromise between the cost of components and the availability of power from the system. One way to do this is to estimate the required **number of days of autonomy**. In the case of a telecommunications system, the number of days of autonomy depends on its critical function within your network design. If the equipment is going to serve as repeater and is part of the backbone of your network, you will likely want to design your photovoltaic system with an autonomy of up to 5-7 days. On the other hand, if the solar system is responsible for providing energy to client equipment you can probably reduce number of days of autonomy to two or three. In areas with low irradiance, this value may need to be increased even more. In any case, you will always have to find the proper balance between cost and reliability.

## Types of batteries

Many different battery technologies exist, and are intended for use in a variety of different applications. The most suitable type for photovoltaic applications is the **stationary battery**, designed to have a fixed location and for scenarios where the power consumption is more or less irregular. "Stationary" batteries can accommodate deep discharge cycles, but they are not designed to produce high currents in brief periods of time.

Stationary batteries can use an electrolyte that is alkaline (such as Nickel-Cadmium) or acidic (such as Lead-Acid). Stationary batteries based on Nickel-Cadmium are recommended for their high reliability and resistance whenever possible. Unfortunately, they tend to be much more expensive and difficult to obtain than sealed lead-acid batteries.

In many cases when it is difficult to find local, good and cheap stationary batteries (importing batteries is not cheap), you will be forced to use batteries targeted to the automobile market.

## Using car batteries

Automobile batteries are not well suited for photovoltaic applications as they are designed to provide a substantial current for just few seconds (when starting then engine) rather than sustaining a low current for long period of time. This design characteristic of car batteries (also called **traction batteries**) results in an shortened effective life when used in photovoltaic systems. Traction batteries can be used in small applications where low cost is the most important consideration, or when other batteries are not available.

Traction batteries are designed for vehicles and electric wheelbarrows. They are cheaper than stationary batteries and can serve in a photovoltaic installation, although they require very frequent maintenance. These batteries should never be deeply discharged, because doing so will greatly reduce their ability to hold a charge. A truck battery should not be discharged by more than 70% of its total capacity. This means that you can only use a maximum of 30% of a lead-acid battery's nominal capacity before it must be recharged.

You can extend the life of a lead-acid battery by using distilled water. By using a densimeter or hydrometer, you can measure the density of the battery's electrolyte. A typical battery has specific gravity of 1.28. Adding distilled water and lowering the density to 1.2 can help reduce the anode's corrosion, at a cost of reducing the overall capacity of the battery. If you adjust the density of battery electrolyte, you **must** use distilled water, as tap water or well water will permanently damage the battery.

## States of charge

There are two special states of charge that can take place during the cyclic charge and discharge of the battery. They should both be avoided in order to preserve the useful life of the battery.

### Overcharge

**Overcharge** takes place when the battery arrives at the limit of its capacity. If energy is applied to a battery beyond its point of maximum charge, the electrolyte begins to break down. This produces bubbles of oxygen and hydrogen, in a process known as **gasification**. This results in a loss of water, oxidation on the positive electrode, and in extreme cases, a danger of explosion.

On the other hand, the presence of gas avoids the stratification of the acid. After several continuous cycles of charge and discharge, the acid tends to concentrate itself at the bottom of the battery thereby reducing the effective capacity. The process of gasification agitates the electrolyte and avoids stratification.

Again, it is necessary to find a compromise between the advantages (avoiding electrolyte stratification) and the disadvantages (losing water and production of hydrogen). One solution is to allow a slight overcharge condition every so often. One typical method is to allow a voltage of 2.35 to 2.4 Volts for each element of the battery every few days, at 25°C. The regulator should ensure a periodical and controlled overcharges.

## Overdischarge

In the same way that there is an upper limit, there is also a lower limit to a battery's state of charge. Discharging beyond that limit will result in deterioration of the battery. When the effective battery supply is exhausted, the regulator prevents any more energy from being extracted from the battery. When the voltage of the battery reaches the minimum limit of 1.85 Volts per cell at 25°C, the regulator disconnects the load from the battery.

If the discharge of the battery is very deep and the battery remains discharged for a long time, three effects take place: the formation of crystallized sulfate on the battery plates, the loosening of the active material on the battery plate, and plate buckling. The process of forming stable sulfate crystals is called hard sulfation. This is particularly negative as it generates big crystals that do not take part in any chemical reaction and can make your battery unusable.

## Battery Parameters

The main parameters that characterize a battery are:

- **Nominal Voltage**,  $V_{NBat}$ : the most common value being 12 V.
- **Nominal Capacity**,  $C_{NBat}$ : the maximum amount of energy that can be extracted from a fully charged battery. It is expressed in Ampere-hours (Ah) or Watt-hours (Wh). The amount of energy that can be obtained from a battery depends on the time in which the extraction process takes place. Discharging a battery over a long period will yield more energy compared to discharging the same battery over a short period. The capacity of a battery is therefore specified at different discharging times. For photovoltaic applications, this time should be longer than 100 hours (C100).
- **Maximum Depth of Discharge**,  $DoD_{max}$ : The depth of discharge is the amount of energy extracted from a battery in a single discharge cycle, expressed as a percentage. The life expectancy of a battery depends on how deeply it is discharged in each cycle. The manufacturer should provide graphs that relate the number of charge-discharge cycles to the life of the battery. As a general rule you should avoid discharging a deep cycle battery beyond 50%. Traction batteries should only be discharged by as little as 30%.
- **Useful Capacity**,  $C_{UBat}$ : It is the real (as in usable) capacity of a battery. It is equal to the product of the nominal capacity and the maximum DoD. For example, a stationary battery of nominal capacity (C100) of 120 Ah and depth of discharge of 70% has a useful capacity of (120 x 0.7) 84 Ah.

## Measuring the state of charge of the battery

A sealed lead-acid battery of 12 V provides different voltages depending on its state of charge. When the battery is fully charged in an open circuit, the output voltage is about 12.8 V. The output voltage lowers quickly to 12.6 V when loads are attached. As the battery is providing constant current during operation, the battery voltage reduces linearly from 12.6 to 11.6 V depending on the state of charge. A sealed lead-acid batteries provides 95% of its energy within this voltage range. If we make the broad assumption that a fully loaded battery has a voltage of 12.6 V when "full" and 11.6 V when "empty", we can estimate that a battery has discharged 70% when it reaches a voltage of 11.9 V. These values are only a rough approximation since they depend on the life and quality of the battery, the temperature, etc.

State of Charge	12V Battery Voltage	Volts per Cell
100%	12.7	2.12
90%	12.5	2.08
80%	12.42	2.07
70%	12.32	2.05
60%	12.2	2.03
50%	12.06	2.01
40%	11.9	1.98
30%	11.75	1.96
20%	11.58	1.93
10%	11.31	1.89
0%	10.5	1.75

According to this table, and considering that a truck battery should not be discharged more than 20% to 30%, we can determine that the useful capacity of a truck 170 Ah truck battery is 34 Ah (20%) to 51 Ah (30%). Using the same table, we find that we should program the regulator to prevent the battery from discharging below 12.3 V.



## Battery and regulator protection

Thermomagnetic circuit breakers or one time fuses must be used to protect the batteries and the installation from short circuit and malfunctions. There are two types of fuses: **slow blow**, and **quick blow**. Slow blow fuses should be used with inductive or capacitive loads where a high current can occur at power up. Slow blow fuses will allow a higher current than their rating to pass for a short time. Quick blow fuses will immediately blow if the current flowing through them is higher than their rating.

The regulator is connected to the battery and the loads, so two different kinds of protection needs to be considered. One fuse should be placed between the battery and the regulator, to protect the battery from short-circuit in case of regulator failure. A second fuse is needed to protect the regulator from excessive load current. This second fuse is normally integrated into the regulator itself.



*Figure 7.9: A battery bank of 3600 Ah, currents reach levels of 45 A during charging*

Every fuse is rated with a maximum current and a maximum usable voltage. The maximum current of the fuse should be 20% bigger than the maximum current expected. Even if the batteries carry a low voltage, a short circuit can lead to a very high current which can easily reach several hundred amperes. Large currents can cause fire, damage the equipment and batteries, and possibly cause electric shock to a human body

If a fuse breaks, never replace a fuse with a wire or a higher rated fuse. First determine the cause of the problem, then replace the fuse with another one which has the same characteristics.

## Temperature effects

The ambient temperature has several important effects on the characteristics of a battery:

- The nominal capacity of a battery (that the manufacturer usually gives for 25°C) increases with temperature at the rate of about 1%/°C. But if the temperature is too high, the chemical reaction that takes place in the battery accelerates, which can cause the same type of oxidation that takes place during overcharging. This will obviously reduce the life expectancy of battery. This problem can be compensated partially in car batteries by using a low density of dissolution (a specific gravity of 1.25 when the battery is totally charged).
- As the temperature is reduced, the useful life of the battery increases. But if the temperature is too low, you run the risk of freezing the electrolyte. The freezing temperature depends on the density of the solution, which is also related to the state of charge of the battery. The lower the density, the greater the risk of freezing. In areas of low temperatures, you should avoid deeply discharging the batteries (that is,  $DoD_{max}$  is effectively reduced.)
- The temperature also changes the relation between voltage and charge. It is preferable to use a regulator which adjusts the low voltage disconnect and reconnect parameters according to temperature. The temperature sensor of the regulator should be fixed to the battery using tape or some other simple method.
- In hot areas it is important to keep the batteries as cool as possible. The batteries must be stored in a shaded area and never get direct sunlight. It's also desirable to place the batteries on a small support to allow air to flow under them, thus increase the cooling.

## How to choose a good battery

Choosing a good battery can be very challenging in developing regions. High capacity batteries are heavy, bulky and expensive to import. A 200 Ah battery weights around 50 kg (120 pounds) and it can not be transported as hand luggage. If you want long-life (as in > 5 years) and maintenance free batteries be ready to pay the price.

A good battery should always come with its technical specifications, including the capacity at different discharge rates (C20, C100), operating temperature, cut-off voltage points, and requirements for chargers.

The batteries must be free of cracks, liquid spillage or any sign of damage, and battery terminals should be free of corrosion. As laboratory tests are

necessary to obtain complete data about real capacity and aging, expect lots of low quality batteries (including fakes) in the local markets. A typical price (not including transport and import tax) is \$3-4 USD per Ah for 12 V lead-acid batteries.

## Life expectancy versus number of cycles

Batteries are the only component of a solar system that should be amortized over a short period and regularly replaced. You can increase the useful lifetime of a battery by reducing the depth of discharge per cycle. Even deep cycle batteries will have an increased battery life if the the number of deep discharge (>30%) cycles is reduced.

If you completely discharge the battery every day, you will typically need to change it after less than one year. If you use only 1/3 of the capacity the battery, it can last more than 3 years. It can be cheaper to buy a battery with 3 times the capacity than to change the battery every year.

## *The power charge regulator*

The power charge regulator is also known as charge controller, voltage regulator, charge-discharge controller or charge-discharge and load controller. The regulator sits between the array of panels, the batteries, and your equipment or loads.

Remember that the voltage of a battery, although always close to 2 V per cell, varies according to its state of charge. By monitoring the voltage of the battery, the regulator prevents overcharging or overdischarging.

Regulators used in solar applications should be connected in series: they disconnect the array of panels from the battery to avoid overcharging, and they disconnect the battery from the load to avoid overdischarging. The connection and disconnection is done by means of switches which can be of two types: electromechanical (relays) or solid state (bipolar transistor, MOSFET). Regulators should never be connected in parallel.

In order to protect the battery from gasification, the switch opens the charging circuit when the voltage in the battery reaches its high voltage disconnect (HVD) or cut-off set point. The low voltage disconnect (LVD) prevents the battery from overdischarging by disconnecting or shedding the load. To prevent continuous connections and disconnections the regulator will not connect back the loads until the battery reaches a low reconnect voltage (LRV).

Typical values for a 12 V lead-acid battery are:

Voltage Point	Voltage
LVD	11.5
LRV	12.6
Constant Voltage Regulated	14.3
Equalization	14.6
HVD	15.5

The most modern regulators are also able to automatically disconnect the panels during the night to avoid discharging of the battery. They can also periodically overcharge the battery to improve their life, and they may use a mechanism known as pulse width modulation (PWM) to prevent excessive gassing.

As the peak power operating point of the array of panels will vary with temperature and solar illumination, new regulators are capable of constantly tracking the maximum point of power of the solar array. This feature is known as maximum power point tracking (MPPT).

## Regulator Parameters

When selecting a regulator for your system, you should at least know the **operating voltage** and the **maximum current** that the regulator can handle. The operating Voltage will be 12, 24, or 48 V. The maximum current must be 20% bigger than the current provided by the array of panels connected to the regulator.

Other features and data of interest include:

- Specific values for LVD, LRV and HVD.
- Support for temperature compensation. The voltage that indicates the state of charge of the battery vary with temperature. For that reason some regulators are able to measure the battery temperature and correct the different cut-off and reconnection values.
- Instrumentation and gauges. The most common instruments measure the voltage of the panels and batteries, the state of charge (SoC) or Depth of Discharge (DoD). Some regulators include special alarms to indicate that the panels or loads have been disconnected, LVD or HVD has been reached, etc.

# Converters

The regulator provides DC power at a specific voltage. Converters and inverters are used to adjust the voltage to match the requirements of your load.

## DC/DC Converters

DC/DC converters transform a continuous voltage to another continuous voltage of a different value. There are two conversion methods which can be used to adapt the voltage from the batteries: **linear conversion** and **switching conversion**.

Linear conversion lowers the voltage from the batteries by converting excess energy to heat. This method is very simple but is obviously inefficient. Switching conversion generally uses a magnetic component to temporarily store the energy and transform it to another voltage. The resulting voltage can be greater, less than, or the inverse (negative) of the input voltage.

The efficiency of a linear regulator decreases as the difference between the input voltage and the output voltage increases. For example, if we want to convert from 12 V to 6 V, the linear regulator will have an efficiency of only 50%. A standard switching regulator has an efficiency of at least 80%.

## DC/AC Converter or Inverter

Inverters are used when your equipment requires AC power. Inverters chop and invert the DC current to generate a square wave that is later filtered to approximate a sine wave and eliminate undesired harmonics. Very few inverters actually supply a pure sine wave as output. Most models available on the market produce what is known as "modified sine wave", as their voltage output is not a pure sinusoid. When it comes to efficiency, modified sine wave inverters perform better than pure sinusoidal inverters.

Be aware that not all the equipment will accept a modified sine wave as voltage input. Most commonly, some laser printers will not work with a modified sine wave inverter. Motors will work, but they may consume more power than if they are fed with a pure sine wave. In addition, DC power supplies tend to warm up more, and audio amplifiers can emit a buzzing sound.

Aside from the type of waveform, some important features of inverters include:

- **Reliability in the presence of surges.** Inverters have two power ratings: one for continuous power, and a higher rating for peak power. They are capable of providing the peak power for a very short amount of time, as when starting a motor. The inverter should also be able to safely interrupt

itself (with a circuit breaker or fuse) in the event of a short circuit, or if the requested power is too high.

- **Conversion efficiency.** Inverters are most efficient when providing 50% to 90% of their continuous power rating. You should select an inverter that most closely matches your load requirements. The manufacturer usually provides the performance of the inverter at 70% of its nominal power.
- **Battery charging.** Many inverters also incorporate the inverse function: the possibility of charging batteries in the presence of an alternative source of current (grid, generator, etc). This type of inverter is known as a charger/inverter.
- **Automatic fall-over.** Some inverters can switch automatically between different sources of power (grid, generator, solar) depending on what is available.

When using telecommunication equipment, it is best to avoid the use of DC/AC converters and feed them directly from a DC source. Most communications equipment can accept a wide range of input voltage.

## *Equipment or load*

It should be obvious that as power requirements increase, the expense of the photovoltaic system also increases. It is therefore critical to match the size of the system as closely as possible to the expected load. When designing the system you must first make a realistic estimate of the maximum consumption. Once the installation is in place, the established maximum consumption must be respected in order to avoid frequent power failures.

## Home Appliances

The use of photovoltaic solar energy is not recommended for heat-exchange applications (electrical heating, refrigerators, toasters, etc.) Whenever possible, energy should be used sparingly using low power appliances.

Here are some points to keep in mind when choosing appropriate equipment for use with a solar system:

- The photovoltaic solar energy is suitable for illumination. In this case, the use of halogen light bulbs or fluorescent lamps is mandatory. Although these lamps are more expensive, they have much better energy efficiency than incandescent light bulbs. LED lamps are also a good choice as they are very efficient and are fed with DC.
- It is possible to use photovoltaic power for appliances that require low and constant consumption (as in a typical case, the TV). Smaller televisions

use less power than larger televisions. Also consider that a black-and-white TV consumes about half the power of a color TV.

- Photovoltaic solar energy is not recommended for any application that transforms energy into heat (thermal energy). Use solar heating or butane as alternative.
- Conventional automatic washing machines will work, but you should avoid the use of any washing programs that include centrifuged water heating.
- If you must use a refrigerators, it should consume as little power as possible. There are specialized refrigerators that work in DC, although their consumption can be quite high (around 1000 Wh/day).

The estimation of total consumption is a fundamental step in sizing your solar system. Here is a table that gives you a general idea of the power consumption that you can expect from different appliances.

Equipment	Consumption (Watts)
Portable computer	30-50
Low power lamp	6-10
WRAP router (one radio)	4-10
VSAT modem	15-30
PC (without LCD)	20-30
PC (with LCD)	200-300
Network Switch (16 port)	6-8

## Wireless telecommunications equipment

Saving power by choosing the right gear saves a lot of money and trouble. For example, a long distance link doesn't necessarily need a strong amplifier that draws a lot of power. A Wi-Fi card with good receiver sensitivity and a fresnel zone that is at least 60% clear will work better than an amplifier, and save power consumption as well. A well known saying of radio amateurs applies here, too: The best amplifier is a good antenna. Further measures to reduce power consumption include throttling the CPU speed, reducing transmit power to the minimum value that is necessary to provide a stable

link, increasing the length of beacon intervals, and switching the system off during times it is not needed.

Most autonomous solar systems work at 12 or 24 volts. Preferably, a wireless device that runs on DC voltage should be used, operating at the 12 Volts that most lead acid batteries provide. Transforming the voltage provided by the battery to AC or using a voltage at the input of the access point different from the voltage of the battery will cause unnecessary energy loss. A router or access point that accepts 8-20 Volts DC is perfect.

Most cheap access points have a switched mode voltage regulator inside and will work through such a voltage range without modification or becoming hot (even if the device was shipped with a 5 or 12 Volt power supply).

**WARNING:** Operating your access point with a power supply other than the one provided by your manufacturer will certainly void any warranty, and may cause damage to your equipment. While the following technique will typically work as described, remember that should you attempt it, you do so at your own risk.

Open your access point and look near the DC input for two relatively big capacitors and an inductor (a ferrite toroid with copper wire wrapped around it). If they are present then the device has a switched mode input, and the maximum input voltage should be somewhat below the voltage printed on the capacitors. Usually the rating of these capacitors is 16 or 25 volts. Be aware that an unregulated power supply has a ripple and may feed a much higher voltage into your access point than the typical voltage printed on it may suggest. So, connecting an unregulated power supply with 24 Volts to a device with 25 Volt-capacitors is not a good idea. Of course, opening your device will void any existing warranty. Do not try to operate an access point at higher voltage if it doesn't have a switched mode regulator. It will get hot, malfunction, or burn.

Equipment based on traditional Intel x86 CPUs are power hungry in comparison with RISC-based architectures as ARM or MIPS. One of the boards with lowest power consumptions is the Soekris platform that uses an AMD ElanSC520 processor. Another alternative to AMD (ElanSC or Geode SC1100) is the use of equipment with MIPS processors. MIPS processors have a better performance than an AMD Geode at the price of consuming between 20-30% of more energy.

The popular Linksys WRT54G runs at any voltage between 5 and 20 volts DC and draws about 6 Watts, but it has an Ethernet switch onboard. Having a switch is of course nice and handy - but it draws extra power. Linksys also offers a Wi-Fi access point called WAP54G that draws only 3 Watts and can run OpenWRT and Freifunk firmware. The 4G Systems Accesscube draws



about 6 Watts when equipped with a single WiFi interface. If 802.11b is sufficient, mini-PCI cards with the Orinoco chipset perform very well while drawing a minimum amount of power.

Equipment	Consumption (Watts)
Linksys WRT54G (BCM2050 radio)	6
Linksys WAP54G (BCM2050 radio)	3
Orinoco WavePoint II ROR (30mW radio)	15
Soekris net4511 (no radio)	1.8
PC Engines WRAP.1E-1 (no radio)	2.04
Mikrotik Routerboard 532 (no radio)	2.3
Inhand ELF3 (no radio)	1.53
Senao 250mW radio	3
Ubiquiti 400mW radio	6

The amount of power required by wireless equipment depends not only on the architecture but on the number of network interfaces, radios, type of memory/storage and traffic. As a general rule, a wireless board of low consumption consumes 2 to 3 W, and a 200 mW radio card consumes as much as 3 W. High power cards (such as the 400 mW Ubiquity) consume around 6 W. A repeating station with two radios can range between 8 and 10 W.

Although the standard IEEE 802.11 incorporates a power saving mode (PS) mechanism, its benefit is not as good as you might hope. The main mechanism for energy saving is to allow stations to periodically put their wireless cards to "sleep" by means of a timing circuit. When the wireless card wakes up it verifies if a beacon exists, indicating pending traffic. The energy saving therefore only takes place in the client side, as the access point always needs to remain awake to send beacons and store traffic for the clients. Power saving mode may be incompatible between implementations from different manufacturers, which can cause unstable wireless connections. It is

nearly always best to leave power saving mode disabled on all equipment, as the difficulties created will likely outweigh the meager amount of saved power.

## Selecting the voltage

Most low power stand-alone systems use 12 V battery power as that is the most common operational voltage in sealed lead-acid batteries. When designing a wireless communication system you need to take into consideration the most efficient voltage of operation of your equipment. While the input voltage can accept a wide range of values, you need to ensure that the overall power consumption of the system is minimal.

## Wiring

An important component of the installation is the wiring, as proper wiring will ensure efficient energy transfer. Some good practices that you should consider include:

- Use a screw to fasten the cable to the battery terminal. Loose connections will waste power.
- Spread Vaseline or mineral jelly on the battery terminals. Corroded connections have an increased resistance, resulting in loss.
- For low currents (<10 A) consider the use of Faston or Anderson power-pole connectors. For bigger currents, use metallic ring lugs.

Wire size is normally given in American Wire Gauge (AWG). During your calculations you will need to convert between AWG and mm<sup>2</sup> to estimate cable resistance. For example, an AWG #6 cable has a diameter of 4.11 mm and can handle up to 55 A. A conversion chart, including an estimate of resistance and current carrying capacity, is available in **Appendix D**. Keep in mind that the current carrying capacity can also vary depending on the type of insulation and application. When in doubt, consult the manufacturer for more information.

## Orientation of the panels

Most of the energy coming from the sun arrives in straight line. The solar module will capture more energy if it is “facing” the sun, perpendicular to the straight line between the position of the installation and the sun. Of course, the sun's position is constantly changing relative to the earth, so we need to find an optimal position for our panels. The orientation of the panels is determined by two angles, the *azimuth*  $\alpha$  and the *inclination* or *elevation*  $\beta$ . The azimuth is the angle that measures the deviation with respect to the

south in the northern hemisphere, and with respect to the north in the southern hemisphere. The inclination is the angle formed by the surface of the module and the horizontal plane.

## Azimuth

You should have the module turned towards the terrestrial equator (facing south in the northern hemisphere, and north in the southern) so that during the day the panel catches the greatest possible amount of radiation ( $\alpha = 0$ ).

It is very important that no part of the panels are ever under shade!. Study the elements that surround the panel array (trees, buildings, walls, other panels, etc.) to be sure that they will not cast a shadow on the panels at any time of the day or year. It is acceptable to turn the panels  $\pm 20^\circ$  towards the east or the west if needed ( $\alpha = \pm 20^\circ$ ).

## Inclination

Once you have fixed the azimuth, the parameter that is key in our calculations is the inclination of the panel, which we will express as the angle beta ( $\beta$ ). The maximum height that the sun reaches every day will vary, with the maximum on the day of the summer solstice and the minimum on the winter solstice. Ideally, the panels should track this variation, but this is usually not possible for cost reasons.

In installations with telecommunications equipment it is normal to install the panels at a fixed inclination. In most telecommunications scenarios the energy demands of the system are constant throughout the year. Providing for sufficient power during the "worst month" will work well for the rest of the year.

The value of  $\beta$  should maximize the ratio between the offer and the demand of energy.

- For installations with consistent (or nearly consistent) consumption throughout the year, it is preferable to optimize the installation to capture the maximum radiation during "the winter" months. You should use the absolute value of the latitude of the place (angle  $F$ ) increased by  $10^\circ$  ( $\beta = |F| + 10^\circ$ ).
- For installations with less consumptions during winter, the value of the latitude of the place can be used as the solar panel inclination. This way the system is optimized for the months of spring and autumn ( $\beta = |F|$ ).
- For installations that are only used during summer, you should use the absolute value of the latitude of the place (angle  $F$ ) decreased by  $10^\circ$  ( $\beta = |F| - 10^\circ$ ). The inclination of the panel should never be less than  $15^\circ$  to avoid the accumulation of dust and/or humidity on the panel. In areas where snow and ice

occur, it is very important to protect the panels and to incline them an angle of 65° or greater.

If there is a considerable increase in consumption during the summer, you might consider arranging for two fixed inclinations, one position for the months of summer and another for the months of winter. This would require special support structures and a regular schedule for changing the position of the panels.

## *How to size your photovoltaic system*

When choosing equipment to meet your power needs, you will need to determine the following, at a minimum:

- The number and type of solar panels required to capture enough solar energy to support your load.
- The minimum capacity of the battery. The battery will need to store enough energy to provide power at night and through days with little sun, and will determine your number of days of autonomy.
- The characteristics of all other components (the regulator, wiring, etc.) needed to support the amount of power generated and stored.

System sizing calculations are important, because unless the system components are balanced, energy (and ultimately, money) is wasted. For example, if we install more solar panels to produce more energy, the batteries should have enough capacity to store the additional energy produced. If the bank of batteries is too small and the load is not using the energy as it is generated, then energy must be thrown away. A regulator of a smaller amperage than needed, or one single cable that is too small, can be a cause of failure (or even fire) and render the installation unusable.

Never forget that the ability of the photovoltaic energy to produce and store electrical energy is limited. Accidentally leaving on a light bulb during the day can easily drain your reserves before nighttime, at which point no additional power will be available. The availability of "fuel" for photovoltaic systems (i.e. solar radiation) can be difficult to predict. In fact, it is never possible to be absolutely sure that a standalone system is going to be able to provide the necessary energy at any particular moment. Solar systems are designed for a certain consumption, and if the user exceeds the planned limits the provision of energy will fail.

The design method that we propose consists of considering the energy requirements, and based on them to calculate a system that works for the maximum amount of time so it is as reliable as possible. Of course, if more

panels and batteries are installed, more energy will be able to be collected and stored. This increase of reliability will also have an increase in cost.

In some photovoltaic installations (such as the provision of energy for telecommunications equipment on a network backbone) the reliability factor is more important than the cost. In a client installation, low cost is likely going to be the most important factor. Finding a balance between cost and reliability is not an easy task, but whatever your situation, you should be able to determine what is expected from your design choices, and at what price.

The method we will use for sizing the system is known as the **method of the worst month**. We simply calculate the dimensions of the standalone system so it will work in the month in which the demand for energy is greatest with respect to the available solar energy. It is the worst month of the year, as this month will have the largest ratio of demanded energy to available energy.

Using this method, **reliability** is taken into consideration by fixing the maximum number of days that the system can work without receiving solar radiation (that is, when all consumption is made solely at the expense of the energy stored in the battery.) This is known as the **maximum number of days of autonomy** (N), and can be thought of as the number of consecutive cloudy days when the panels do not collect any significant amount of energy.

When choosing N, it is necessary to know the climatology of the place, as well as the economic and social relevance of the installation. Will it be used to illuminate houses, a hospital, a factory, for a radio link, or for some other application? Remember that as N increases, so does the investment in equipment and maintenance. It is also important to evaluate all possible logistical costs of equipment replacement. It is not the same to change a discharged battery from an installation in the middle of a city versus one at the top of a telecommunication tower that is several hours or days of walking distance.

Fixing the value of N it is not an easy task as there are many factors involved, and many of them cannot be evaluated easily. Your experience will play an important role in this part of the system sizing. One commonly used value for critical telecommunications equipment is  $N = 5$ , whereas for low cost client equipment it is possible to reduce the autonomy to  $N = 3$ .

In **Appendix E**, we have included several tables that will facilitate the collection of required data for sizing the system. The rest of this chapter will explain in detail what information you need to collect or estimate and how to use the method of the "worst month".

## Data to collect

- **Latitude of the installation.** Remember to use a positive sign in the northern hemisphere and negative in the south.
- **Solar radiation data.** For the method of the "worst month" it is enough to know just twelve values, one for every month. The twelve numbers are the monthly average values of daily global irradiation on horizontal plane ( $G_{dm}(0)$ , in kWh/m<sup>2</sup> per day). The monthly value is the sum of the values of global irradiation for every day of the month, divided by the number of days of the month.

If you have the data in Joules (J), you can apply the following conversion:

$$1 \text{ J} = 2.78 \times 10^{-7} \text{ kWh}$$

The irradiation data  $G_{dm}(0)$  of many places of the world is gathered in tables and databases. You should check for this information from a weather station close to your implementation site, but do not be surprised if you cannot find the data in electronic format. It is a good idea to ask companies that install photovoltaic systems in the region, as their experience can be of great value.

Do not confuse "sun hours" with the number of "peak sun hours". The number of peak sun hours has nothing to do with the number of hours without clouds, but refers to the amount of daily irradiation. A day of 5 hours of sun without clouds does not necessary have those hours when the sun is at its zenith.

A peak sun hour is a normalized value of solar radiation of 1000 W/m<sup>2</sup> at 25 C. So when we refer to 5 peak sun hours, this implies a daily solar radiation of 5000 W/m<sup>2</sup>.

## Electrical characteristics of system components

The electrical characteristics of the components of your system should be provided by the manufacturer. It is advisable to make your own measurements to check for any deviation from the nominal values. Unfortunately, deviation from promised values can be large and should be expected.

These are the minimum values that you need to gather before starting your system sizing:

### Panels

You need to know the voltage  $V_{Pmax}$  and the current  $I_{Pmax}$  at the point of maximum power in standard conditions.

## Batteries

Nominal capacity (for 100 hours discharge)  $C_{NBat}$ , operational voltage  $V_{NBat}$ , and either the maximum depth of discharge  $DoD_{max}$  or useful capacity  $C_{UBat}$ . You also need to know the type of battery that you plan to use, whether sealed lead-acid, gel, AGM, modified traction etc. The type of battery is important when deciding the cut-off points in the regulator.

## Regulator

You need to know the nominal voltage  $V_{NReg}$ , and the maximum current that can operate  $I_{maxReg}$ .

## DC/AC Converter/Inverter

If you are going to use a converter, you need to know the nominal voltage  $V_{NConv}$ , instantaneous power  $P_{IConv}$  and performance at 70% of maximum load  $H_{70}$ .

## Equipment or load

It is necessary to know the nominal voltage  $V_{NC}$  and the nominal power of operation  $P_C$  for every piece of equipment powered by the system.

In order to know the total energy that our installation is going to consume, it is also very important to consider the average time each load will be used. Is it constant? Or will it be used daily, weekly, monthly or annually? Consider any changes in the usage that might impact the amount of energy needed (seasonal usage, training or school periods, etc.)

## Other variables

Aside from the electrical characteristics of the components and load, it is necessary to decide on two more pieces of information before being able to size a photovoltaic system. These two decisions are the required number of days of autonomy and the operational voltage of the system.

### N, number of days of autonomy

You need to decide on a value for N that will balance meteorological conditions with the type of installation and overall costs. It is impossible to give a concrete value of N that is valid for every installation, but the next table gives some recommended values. Take these values as a rough approximation, and consult with an experienced designer to reach a final decision.

Available Sunlight	Domestic Installation	Critical Installation
Very cloudy	5	10
Variable	4	8
Sunny	3	6

### $V_N$ , nominal voltage of the installation

The components of your system need to be chosen to operate at a nominal voltage  $V_N$ . This voltage is usually 12 or 24 Volts for small systems, and if the total power of consumption surpasses 3 kW, the voltage will be 48 V. The selection of  $V_N$  is not arbitrary, and depends on the availability of equipment.

- If the equipment allows it, try to fix the nominal voltage to 12 or 24 V. Many wireless communications boards accept a wide range of input voltage and can be used without a converter.
- If you need to power several types of equipment that work at different nominal voltages, calculate the voltage that minimizes the overall power consumption including the losses for power conversion in DC/DC and DC/AC converters.

### Procedure of calculation

There are three main steps that need to be followed to calculate the proper size of a system:

1. **Calculate the available solar energy (the offer).** Based on statistical data of solar radiation, and the orientation and the optimal inclination of the solar panels, we calculate the solar energy available. The estimation of solar energy available is done in monthly intervals, reducing the statistical data to 12 values. This estimation is a good compromise between precision and simplicity.
2. **Estimate the required electrical energy (the demand).** Record the power consumption characteristics of the equipment chosen as well as estimated usage. Then calculate the electrical energy required on a monthly basis. You should consider the expected fluctuations of usage due to the variations between winter and summer, the rainy period / dry season, school / vacation periods, etc. The result will be 12 values of energy demand, one for each month of the year.



3. **Calculate the ideal system size (the result).** With the data from the “worst month”, when the relation between the solar demanded energy and the energy available is greatest, we calculate:
- The current that the array of panels needs to provide, which will determine the minimum number of panels.
  - The necessary energy storage capacity to cover the minimum number of days of autonomy, which will determine the required number of batteries.
  - The required electrical characteristics of the regulator.
  - The length and the necessary sections of cables for the electrical connections.

### Required current in the worst month

For each month you need to calculate the value of  $I_m$ , which is the maximum daily current that an array of panels operating at nominal voltage of  $V_N$  needs to provide, in a day with a irradiation of  $G_{dm}$  for month "m", for panels with an inclination of  $\beta$  degrees..

The  $I_m$  (WORST MONTH) will be the largest value of  $I_m$ , and the system sizing is based on the data of that worst month. The calculations of  $G_{dm}(\beta)$  for a certain place can be made based on  $G_{dm}(0)$  using computer software such as PVSYST (<http://www.pvsyst.com/>) or PVSOL (<http://www.solardesign.co.uk/>).

Due to losses in the regulator and batteries, and due to the fact that the panels do not always work at the point of maximum power, the required current  $I_{mMAX}$  is calculated as:

$$I_{mMAX} = 1.21 I_m \text{ (WORST MONTH)}$$

Once you have determined the worst month, the value of  $I_{mMAX}$ , and the total energy that you require  $E_{TOTAL}$  (WORST MONTH) you can proceed to the final calculations.  $E_{TOTAL}$  is the sum of all DC and AC loads, in Watts. To calculate  $E_{TOTAL}$  see **Appendix E**.

### Number of panels

By combining solar panels in series and parallel, we can obtain the desired voltage and current. When panels are connected in series, the total voltage is equal to the sum of the individual voltages of each module, while the current remains unchanged. When connecting panels in parallel, the currents are

summed together while the voltage remains unchanged. It is very important, to use panels of nearly identical characteristics when building an array.

You should try to acquire panels with  $V_{Pmax}$  a bit bigger than the nominal voltage of the system (12, 24 or 48 V). Remember that you need to provide a few volts more than the nominal voltage of the battery in order to charge it. If it is not possible to find a single panel that satisfies your requirements, you need to connect several panels in series to reach your desired voltage. The number of panels in series  $N_{ps}$  is equal to the nominal voltage of the system divided by the voltage of a single panel, rounded up to the nearest integer.

$$N_{ps} = V_N / V_{Pmax}$$

In order to calculate the number of panels in parallel ( $N_{pp}$ ), you need to divide the  $I_{mMAX}$  by the current of a single panel at the point of maximum power  $I_{pmax}$ , rounded up to the nearest integer.

$$N_{pp} = I_{mMAX} / I_{pmax}$$

The total number of panels is the result of multiplying the number of panels in series (to set the voltage) by the number of panels in parallel (to set the current).

$$N_{TOTAL} = N_{ps} \times N_{pp}$$

## Capacity of the battery or accumulator

The battery determines the overall voltage of the system and needs to have enough capacity to provide energy to the load when there is not enough solar radiation.

To estimate the capacity of our battery, we first calculate the required energy capacity of our system (necessary capacity,  $C_{NEC}$ ). The necessary capacity depends on the energy available during the "worst month" and the desired number of days of autonomy (N).

$$C_{NEC} \text{ (Ah)} = E_{TOTAL} \text{ (WORST MONTH) (Wh)} / V_N \text{ (V)} \times N$$

The nominal capacity of the battery  $C_{NOM}$  needs to be bigger than the  $C_{NEC}$  as we cannot fully discharge a battery. To calculate the size of the battery we need to consider the maximum depth of discharge (DoD) that the battery allows:

$$C_{NOM} \text{ (Ah)} = C_{NEC} \text{ (Ah)} / DoD_{MAX}$$

In order to calculate the number of batteries in series ( $N_{bs}$ ), we divide the nominal voltage of our installation ( $V_N$ ) by the nominal voltage of a single battery ( $V_{NBat}$ ):

$$N_{bs} = V_N / V_{NBat}$$

## Regulator

One important warning: always use regulators in series, never in parallel. If your regulator does not support the current required by your system, you will need to buy a new regulator with a larger working current.

For security reasons, a regulator needs to be able to operate with a current  $I_{maxReg}$  at least 20% greater than the maximum intensity that is provided by the array of panels:

$$I_{maxReg} = 1.2 N_{pp} I_{PMax}$$

## DC/AC Inverter

The total energy needed for the AC equipment is calculated including all the losses that are introduced by the DC/AC converter or inverter. When choosing an inverter, keep in mind that the performance of the inverter varies according to the amount of requested power. An inverter has better performance characteristics when operating close to its rated power. Using a 1500 Watt inverter to power a 25 Watt load is extremely inefficient. In order to avoid this wasted energy, it is important to consider not the peak power of all your equipment, but the peak power of the equipment that is expected to operate simultaneously.

## Cables

Once you know the numbers of panels and batteries, and type of regulators and inverters that you want to use, it is necessary to calculate the length and the thickness of the cables needed to connect the components together.

The **length** depends on the location of your the installation. You should try to minimize the length of the cables between the regulator, panels, and batteries. Using short cables will minimize lost power and cable costs.

The **thickness** is chosen is based on the length of the cable and the maximum current it must carry. The goal is to minimize voltage drops. In order to calculate the thickness  $S$  of the cable it is necessary to know:

- The maximum current  $I_{MC}$  that is going to circulate in the cable. In the case of the panel-battery subsystem, it is  $I_{mMAX}$  calculated for every month. In the battery-load subsystem it depends on the way that the loads are connected.
- The voltage drop ( $V_a - V_b$ ) that we consider acceptable in the cable. The voltage drop that results of adding all possible individual drops is expressed as a percent of the nominal voltage of the installation. Typical maximum values are:

Component	Voltage Drop (% of $V_N$ )
Panel Array -> Battery	1%
Battery -> Converter	1%
Main Line	3%
Main Line (Illumination)	3%
Main Line (Equipment)	5%

### Typical acceptable voltage drops in cables

The section of the cable is determined by Ohm's Law:

$$S (\text{mm}^2) = r (\Omega\text{mm}^2/\text{m}) L (\text{m}) I_{mMAX} (\text{A}) / (V_a - V_b) (\text{V})$$

where  $S$  is the section,  $r$  is resistivity (intrinsic property of the material: for copper,  $0.01286 \Omega\text{mm}^2/\text{m}$ ), and  $L$  the length.

$S$  is chosen taking into consideration the cables available in the market. You should choose the immediately superior section to the one that is obtained from the formula. For security reasons that are some minimum values, for the cable that connects panels and battery, this is a minimum of  $6 \text{ mm}^2$ . For the other sections, that minimum is  $4 \text{ mm}^2$ .

## Cost of a solar installation

While solar energy itself is free, the equipment needed to turn it into useful electric energy is not. You not only need to buy equipment to transform the solar energy in electricity and store it for use, but you must also replace and maintain various components of the system. The problem of equipment

replacement is often overlooked, and a solar system is implemented without a proper maintenance plan.

In order to calculate the real cost of your installation, we include an illustrative example. The first thing to do it is to calculate the initial investment costs.

Description	Number	Unit Cost	Subtotal
60W Solar panel (about \$4 / W)	4	\$300	\$1,200
30A Regulator	1	\$100	\$100
Wiring (meters)	25	\$1 / meter	\$25
50 Ah Deep cycle batteries	6	\$150	\$900
<b>Total:</b>			<b>\$2,225</b>

The calculation of our investment cost is relatively easy once the system has been dimensioned. You just need to add the price for each piece equipment and the labor cost to install and wire the equipments together. For simplicity, we do not include the costs of transport and installation but you should not overlook them.

To figure out how much a system will really cost to operate we must estimate how long each part will last and how often you must replace it. In accounting terminology this is known as *amortization*. Our new table will look like this:

Description	#	Unit Cost	Subtotal	Lifetime (Years)	Yearly Cost
60W Solar panel	4	\$300	\$1,200	20	\$60
30A Regulator	1	\$100	\$100	5	\$20
Wiring (meters)	25	\$1 / meter	\$25	10	\$2.50
50 Ah Deep cycle batteries	6	\$150	\$900	5	\$180
<b>Total:</b>			<b>\$2,225</b>	<b>Annual Cost:</b>	<b>\$262.50</b>

As you see, once the first investment has been done, an annual cost of \$262.50 is expected. The annual cost is an estimation of the required capital per year to replace the system components once they reach the end of their useful life.